

MOSCA®

EXCELLENCE IN STRAPPING SOLUTIONS



Evolution SoniXs MS-6
Automatic Side-Seal Strapping Machine

SONIXS MS-6

STANDARD FEATURES

- Ultrasonic sealing system with electronic self-calibration
- Can be integrated into most production lines
- High-end Standard 6 sealing unit
- Easy accessibility and tool-free disassembly of strap path components
- Dispenser variably mountable
- Hinged table top made of stainless steel
- Adjustable strap tension via control panel
- Easy operation via digital display in the control panel
- Manual strapping release via pushbutton in the control panel
- Stepless turnable control panel (0°-180°) for many-sided operation
- 4 castors
- Extremely low energy consumption
- Structural coating RAL 5010, gentian blue

OPTIONS

- Flexible foot switch for manual strap release
- Pneumatic hold-down device
- Pneumatic side-pusher
- Sealing unit for low products (heat-welding)
- Automatic adjustment of the strap tension by package height detection
- Two- or three-part signal light (LED)
- Low strap detection with signal in the control panel
- Signal exchange via 16-pole contact plug to integrate into fully automatic production lines
- Fully automatic strap coil change by double strap dispenser
- Middle rollers
- Special conveying heights
- Special coating according to RAL scale

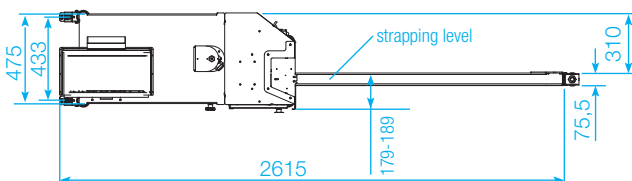

TECHNICAL DATA

PERFORMANCE:

Up to 52 cycles per minute (550 mm x 500 mm)

FRAME SIZES: [W x H]

450 mm x 400 mm
 550 mm x 500 mm
 650 mm x 600 mm
 900 mm x 600 mm / 1400 mm / 1800 mm
 1300 mm x 600 mm / 1000 mm / 1400 mm / 1800 mm / 2200 mm
 1650 mm x 600 mm / 1800 mm

CONVEYING HEIGHT:

310 mm to 560 mm (standard)
 360 mm to 1110 mm (optional increased working height)

STRAPS:

Standard machine grade 5 - 15 mm wide PP straps or
 Standard machine grade 9.5 - 15 mm wide PET straps

STRAP COIL DISPENSER:

Core diameter: 200 mm (optional 406 mm PET)
 Core width: 190 mm (optional 150 mm PET)

ELECTRICITY:

Voltage: 100-240 V, 50/60 Hz, 1L+N+PE
 Power consumption: approx. 0.2 kW

WEIGHT: 205 kg – 300 kg

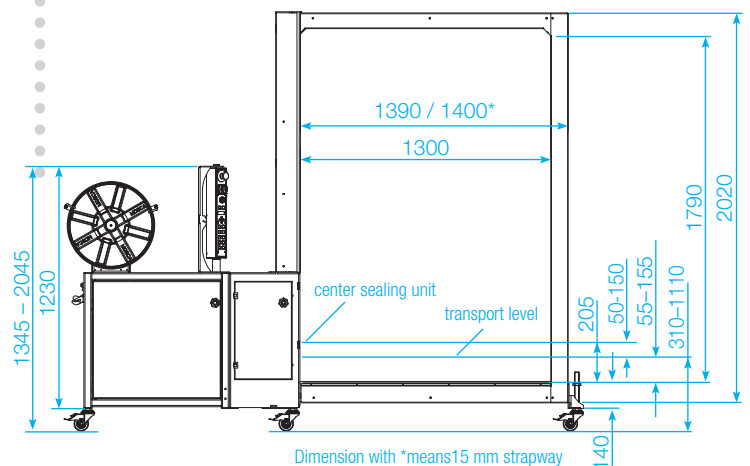

Frame size (1300 x 1800 mm)

MOSCA[®]
 EXCELLENCE IN STRAPPING SOLUTIONS

MOSCA GMBH

Gerd-Mosca-Straße 1
 D-69429 Waldbrunn/Germany
 Tel.: +49 6274/932-0
 Fax: +49 6274/932-400 118
 Tel. Tech. Service: +49 6274 / 932-146
 E-Mail: info@mosca.com
 Internet: www.mosca.com

12 / 19 Subject to Alterations

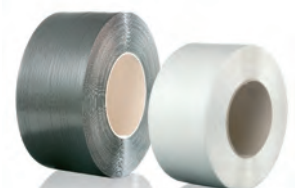

The models of MS-6 are adjustable to one strap width of all quality PP straps of 5, 6, 8, 9, 10, 12, 15 mm or quality PET straps of 9.5 - 15 mm. Obtainable directly from Mosca, produced in one of Europe's most modern manufacturing plants. Combinable with maintenance contracts by Mosca - a one-stop solution.